

## REAR AXLE IDENTIFICATION GUIDE

This guide can be used to help identify your rear axle make/model. This information should help you locate the Auburn Gear differential model appropriate for your vehicle.

### AMC

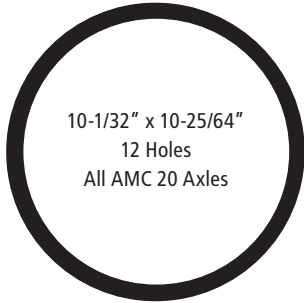

AMC 20

### CHRYSLER



CHRYSLER 8-1/4" , 8-3/8"

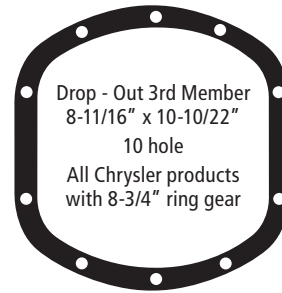

CHRYSLER 8-3/4"

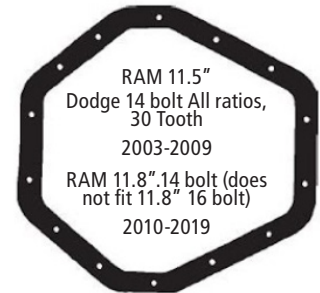

CHRYSLER DODGE RAM AND  
RAM AAM 11-1/2"

### CHRYSLER

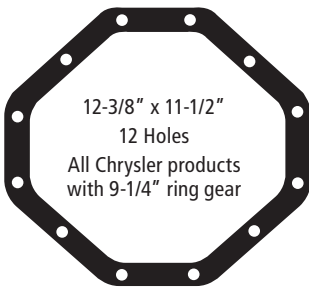

CHRYSLER 9-1/4"

### DANA

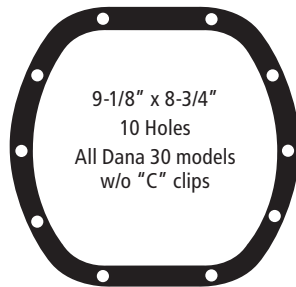

DANA 30

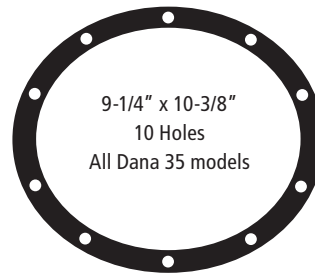

DANA 35

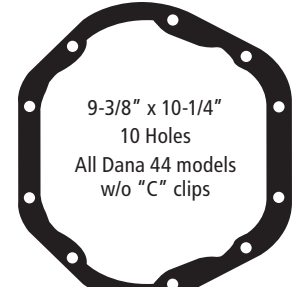

DANA 44

### DANA

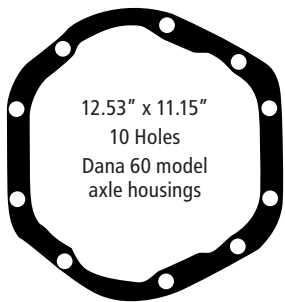

DANA 50/DANA 60



DANA 70



DANA 80

### FORD



FORD 7-1/2"

### FORD

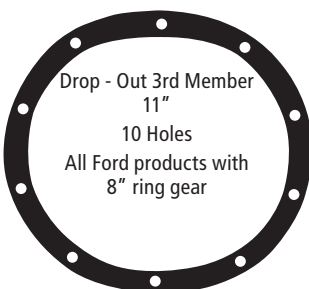

FORD 8"

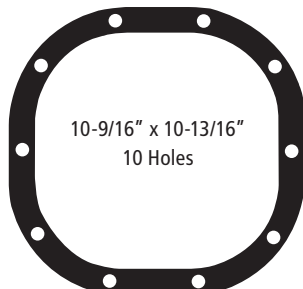

FORD 8.8"



FORD 9"

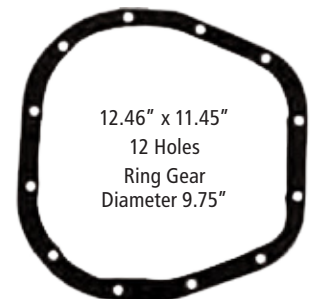

FORD 9-3/4"

**FORD**

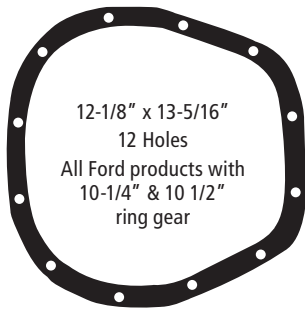

12-1/8" x 13-5/16"  
12 Holes  
All Ford products with  
10-1/4" & 10 1/2"  
ring gear

**FORD 10-1/4", 10-1/2"**

**GENERAL MOTORS**



8-5/16" x 10-9/16"  
10 Holes  
All GM products with  
7-1/2" & 7-5/8"  
ring gear.

**GM 7-1/2", 7-5/8"**



11-1/2"  
10 Holes  
Chevrolet with 8.2"  
ring gear.  
Chevy, Buick, Pontiac, Olds

**CHEVY 8.2", BOP 8.2**



11"  
10 Holes  
All GM products with  
8.5" & 8.6" ring gear.

**GM 8-1/2", 8.6 FRONT**

**GENERAL MOTORS**



10-5/8"  
10 Holes  
All GM products with  
8.5" & 8.6" ring gear.

**GM 8.5/8.6" REAR**

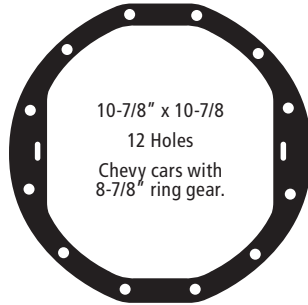

10-7/8" x 10-7/8"  
12 Holes  
Chevy cars with  
8-7/8" ring gear.

**GM 8-7/8" 12 BOLT CAR**

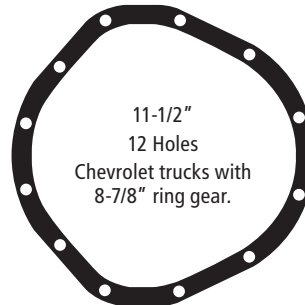

11-1/2"  
12 Holes  
Chevrolet trucks with  
8-7/8" ring gear.

**GM 8-7/8" 12 BOLT TRUCK**

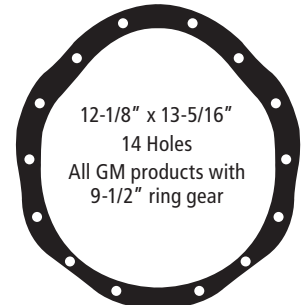

12-1/8" x 13-5/16"  
14 Holes  
All GM products with  
9-1/2" ring gear

**GM 9-1/2"**

**GENERAL MOTORS**



30 Tooth  
All ratios, 14 bolt  
Fits 2001-2019

**GM AAM 11-1/2"**

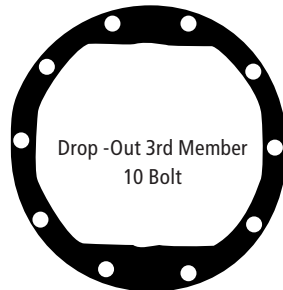

Drop -Out 3rd Member  
10 Bolt

**GM 8.2"/8.4" 1955-1964 CHEVY**

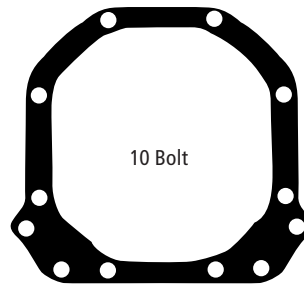

10 Bolt

**1963-1979 CORVETTE**



**TOYOTA**

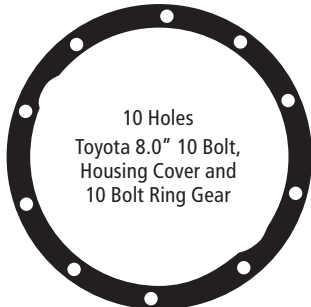

**TOYOTA 8**



**TOYOTA 8.4**

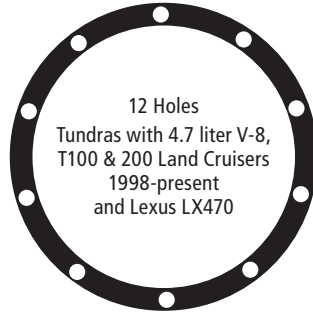

**TOYOTA 9-1/2**

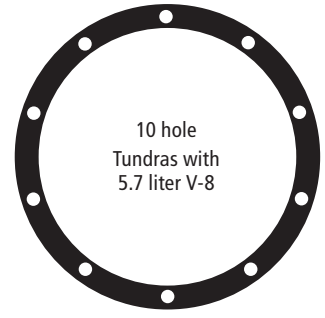

**TOYOTA 10.5**

**TOYOTA**

**NISSAN**

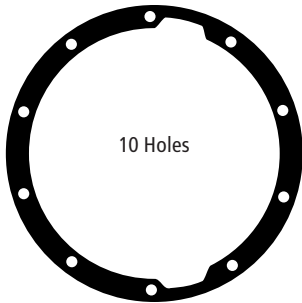

**1968-1979 LAND CRUISER**

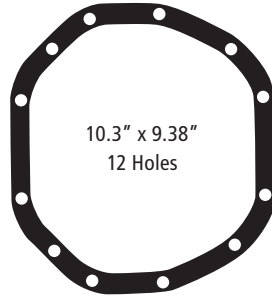

**NISSAN TITAN**

